

Lift&Drive Data Centre Lifter

Technical data



Technical data

Model	DC15 U42	DC15 U60	DC09 U42	DC09 U52
Load type	Server or battery			
Max load including tool (kg)	150	150	90	90
Max lifting speed full (mm/s)	78	65/78*	132	132/83*
Platform type	Sliding or fixed		Fixed	
Height in "U"	42	60	42	52
Minimum height in "U"	1			
Weight (kg)	91	118	65	85
Front wheel	Swivel (std) or fixed			
Min turning radius** (mm)	Ø1095	Ø1222	Ø887	Ø1126
Safety regulations	CE 42/2006			

* For the telescopic column

** Central pivotal point calculated as center point between the diagonal swivel wheel pair

Batteries

Battery	Sealed, valve regulated, lead-acid batteries (VRLA)
Nominal battery voltage	24V DC (12V x 2)
Battery capacity	12Ah
Nominal charge voltage	27.6V stand-by. 29V max voltage.
Nominal charge current	1350 mA - 2400 mA
Available plugs with charger*	Plug Type A – North America Plug Type C – Europe Plug Type G – UK Plug Type I – AU / NZ

* The charger is CE/UL/UKCA/SAA

Options

Model	DC15 U42	DC15 U60	DC09 U42	DC09 U52
Model article no.	19154B-10/20	19156B-10/20	200942B-20	200952B-20
Platform	Sliding/Fixed	Sliding/Fixed	Fixed	Fixed
Changes in height	•	•	•	•
Adjustable top switch	-	220641	-	220640
Sound signal	-	•	-	•
Light indication	-	•	-	•
ESD	•	•	•	•
Transfer rails	220647			
Safety Strap Unit	220650		-	-
Ladder	•	•	-	-
Raised profile 50mm	220648			
Charging station	220446			

• = Made to order

Dimensions DC15 U42-10

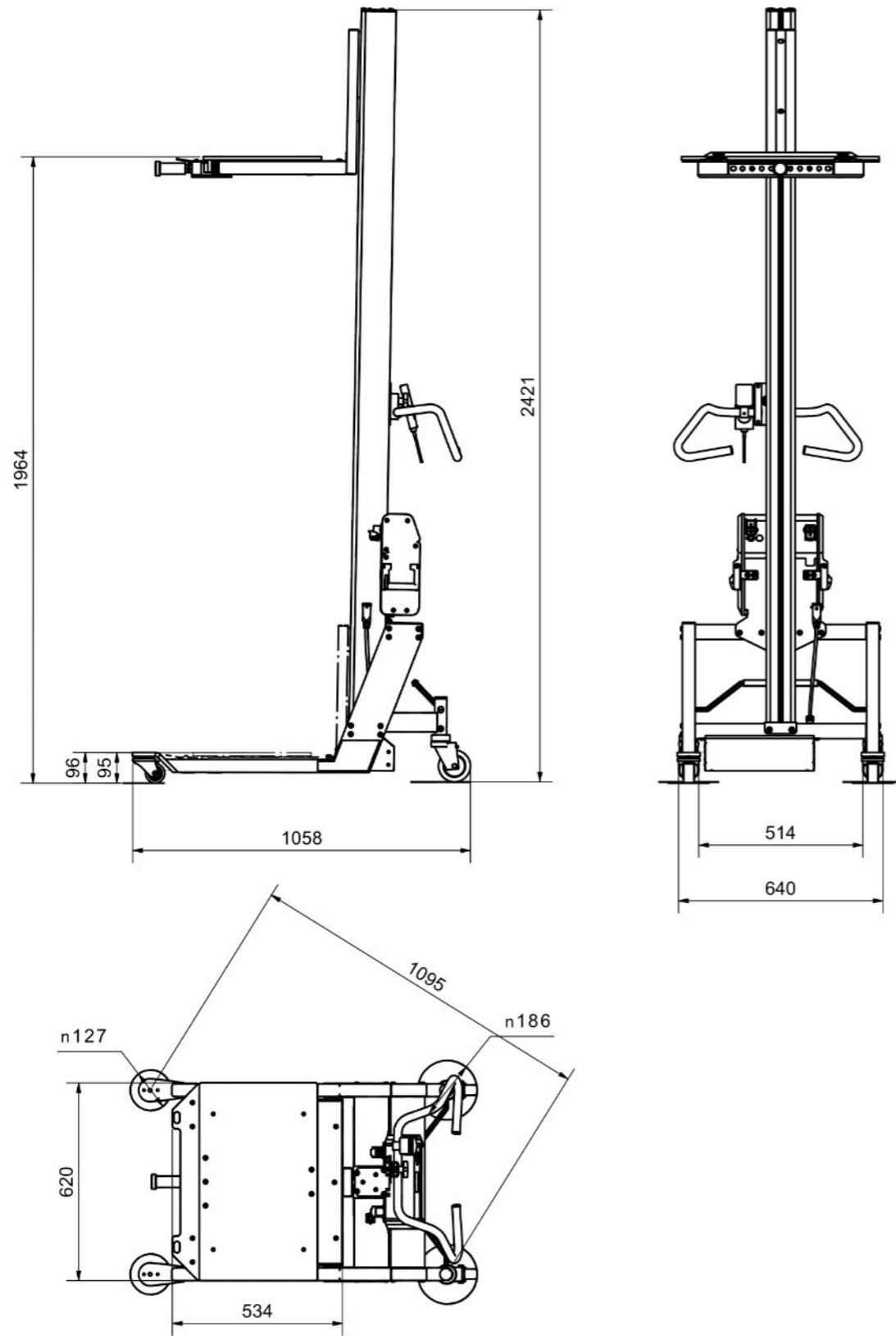

Dimensions DC15 U42-20

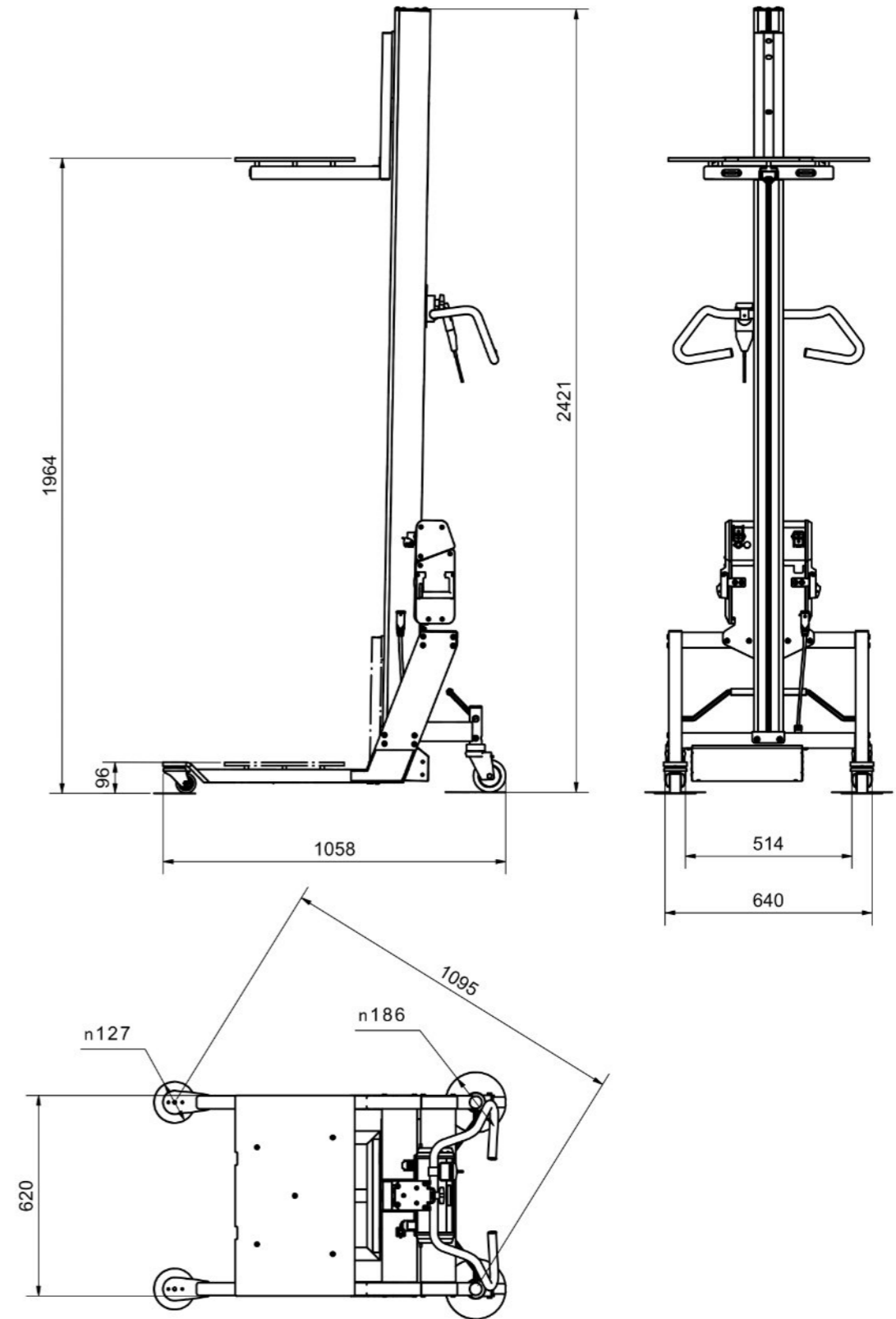

Dimensions DC15 U60-10

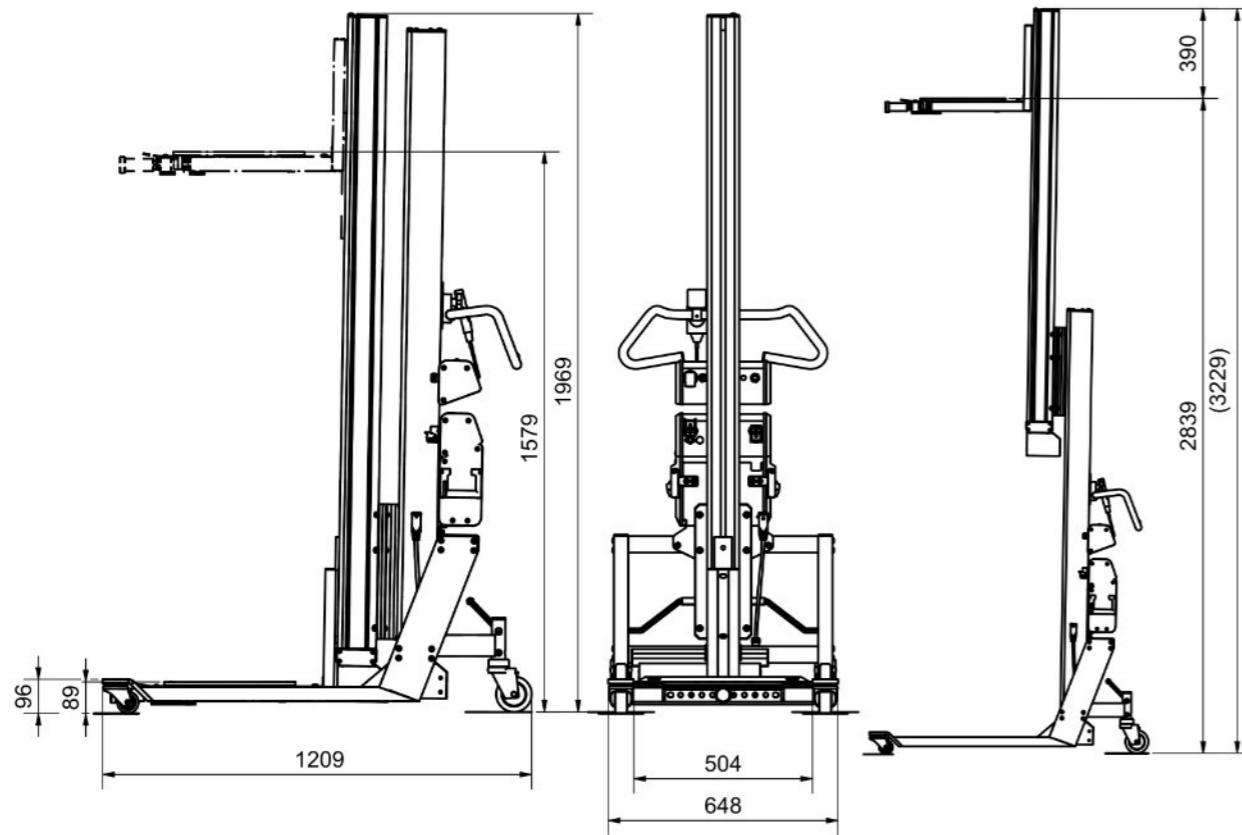

Dimensions DC15 U60-20

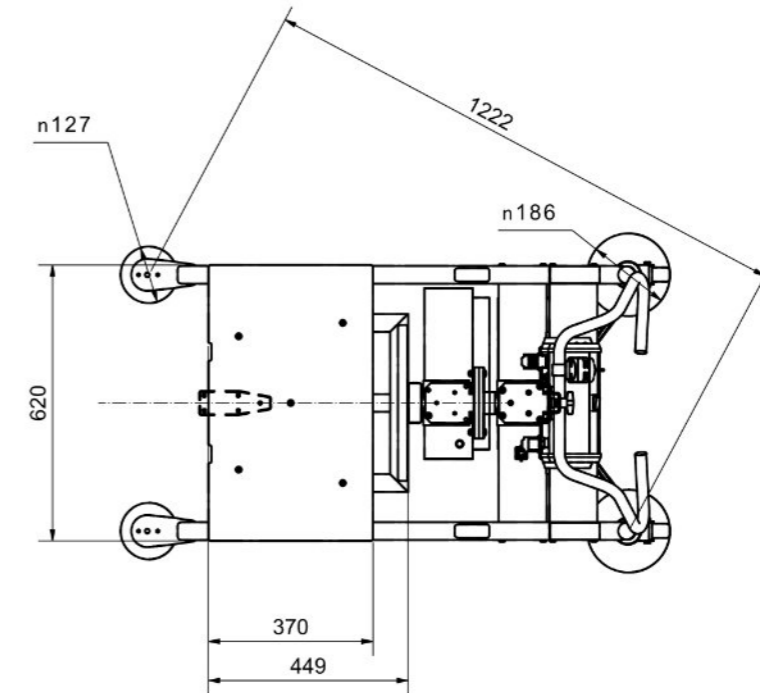
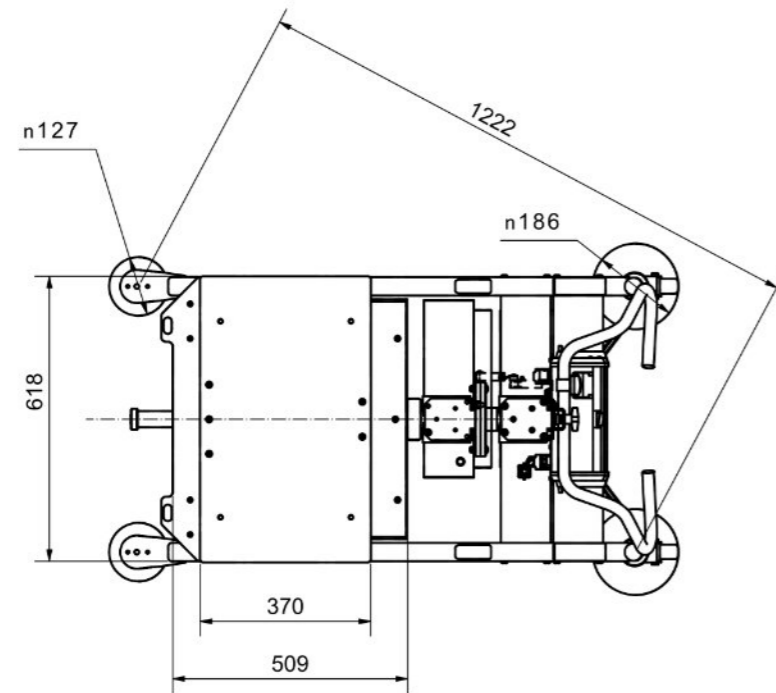
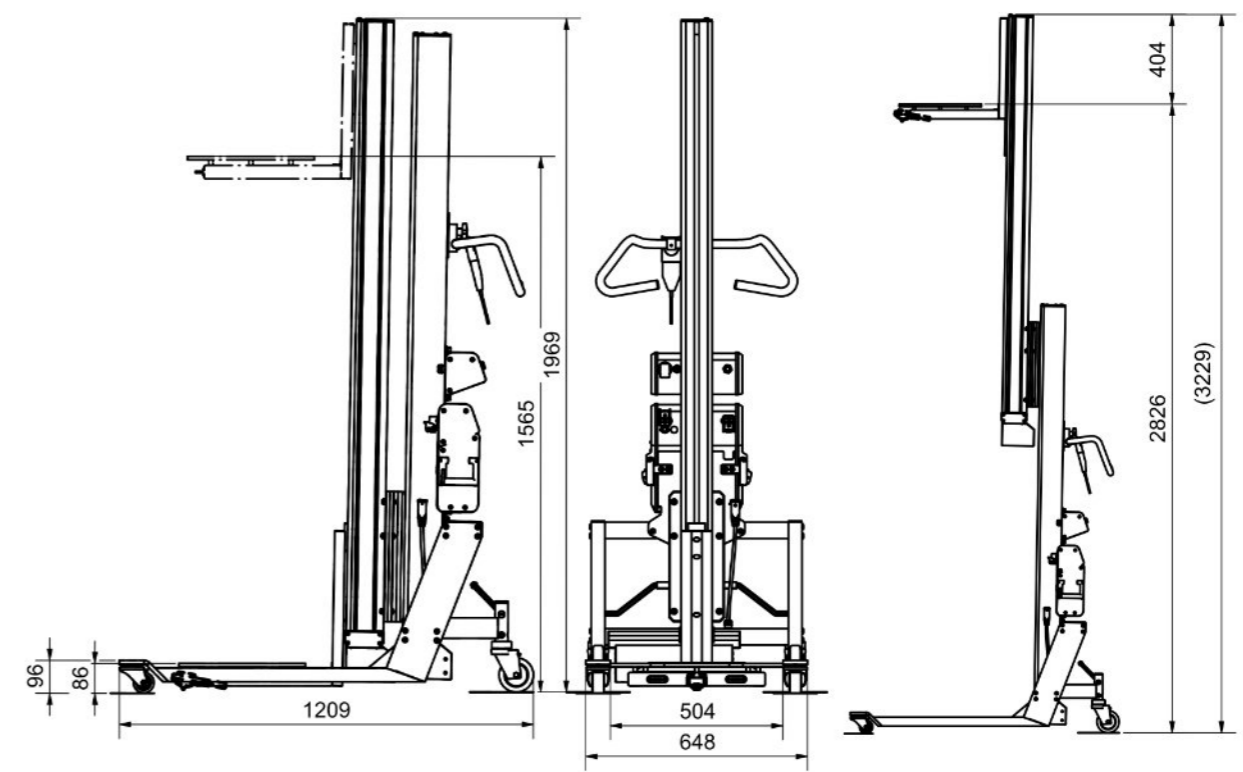

Dimensions DC09 U42-20

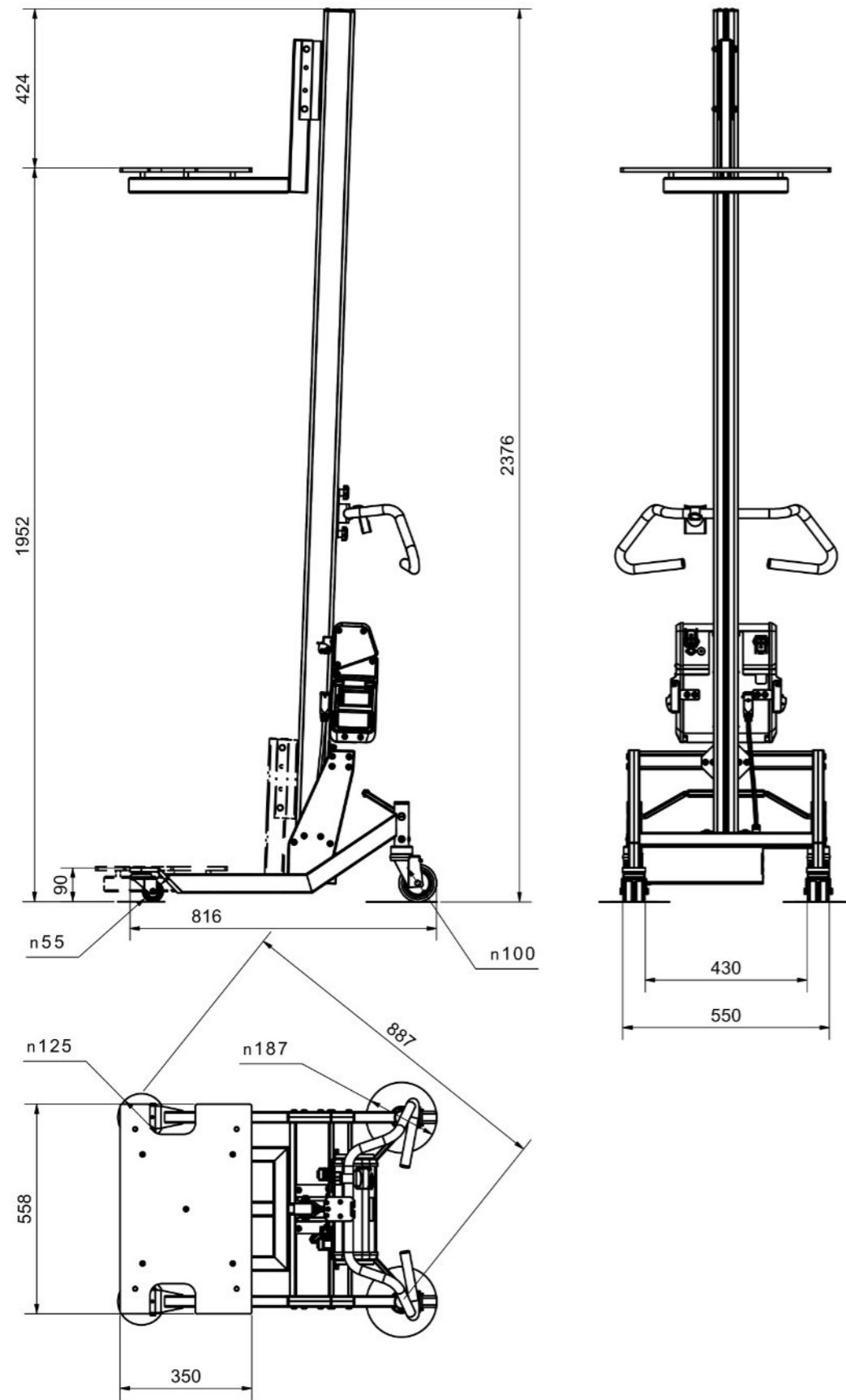

Dimensions DC09 U52-20

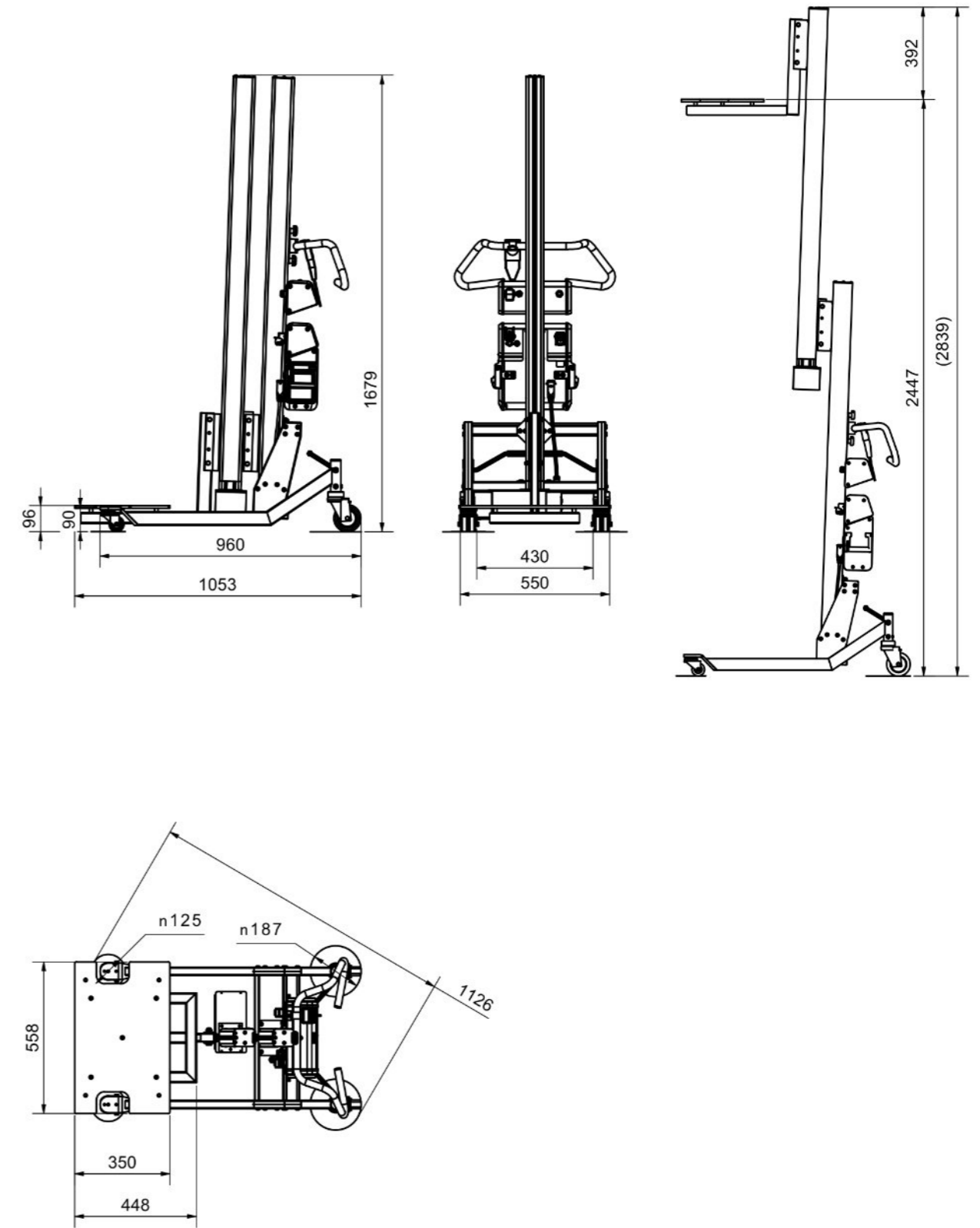

Disclaimer. We reserve the right to make changes. Illustrations, drawings and data are not always in accordance with the latest version or standard model in production. The models in the pictures may present special equipment or colours.

Smart moves
For safe work

PRONOMIC
pronomic.com
Present with sales and service in FLAPD area